

# DCB Blender Specifications and Dimensions

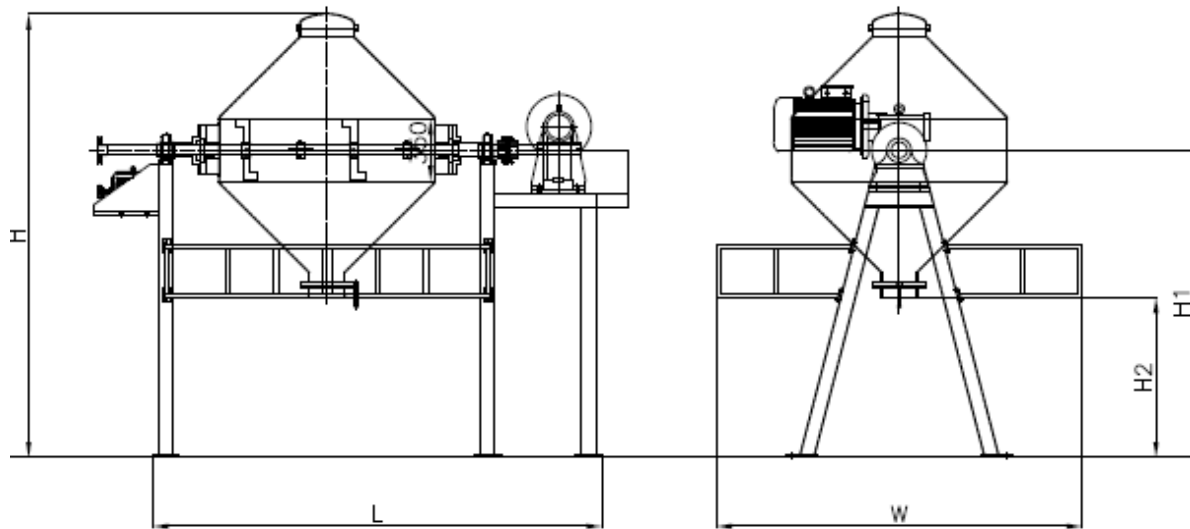

## STANDARD FEATURES

- Double Cone design in 316 stainless steel construction
- Manually operated Butterfly valve for discharge 24" discharge clearance
- Hinged stainless steel charging opening
- Mirror finish on interior surfaces
- 150 grit finish on exterior surfaces
- Non-stainless steel components are finished with a durable two-component paint.
- Safety railings with limit switches
- Intensifier bars are included
- Drive motors are of TEFC design for 230/460 volt , 3 ph, 60 Hz operation
- Complete control panels with pushbuttons and E-stops are provided

DCB Blender Model	Full Holding Capacity		Working Capacity		HP	RPM	Overall Dimensions				
	Cu.Ft.	Liters	Cu.Ft.	Liters			Length L	Width W	Height H	Height H1	Height H2
DCB 0.25	0.4	10.6	0.25	7.1	0.25	36	30.0	26.0	36.0	26.0	18.0
DCB 0.5	0.7	21.1	0.5	14.2	0.5	36	36.0	29.0	39.0	28.0	18.0
DCB 1.0	1.5	42.3	1	28.3	1	24	45.0	37.0	47.0	36.0	20.0
DCB 5.0	7.5	211.3	5	141.6	3	16	79.0	65.0	83.0	59.0	36.0
DCB 7.5	11.0	311.5	7.5	212.4	2	16	85.0	70.0	83.0	61.0	36.0
DCB 10	15.0	424.8	10	283.2	2	16	106.0	68.9	91.0	65.0	36.0
DCB 15	22.5	637.2	15	424.8	5	16	118.0	81.0	98.0	69.0	36.0
DCB 20	30.0	849.6	20	566.4	7.5	16	118.0	87.0	103.0	71.0	36.0
DCB 25	37.0	1047.8	25	708.0	10	12	126.0	91.0	110.0	76.8	36.0
DCB 30	45.0	1274.4	30	849.6	12.5	12	135.0	98.0	118.0	83.0	36.0
DCB 50	75.0	2124.0	50	1416.0	15	10	150.0	114.0	126.0	83.0	36.0
DCB 75	112.0	3171.8	75	2124.0	30	8	158.0	126.0	142.0	91.0	36.0
DCB 100	150.0	4248.0	100	2832.0	40	8	185.0	137.8	150.0	95.0	36.0



**Charles Ross & Son Company**

P.O.Box 12308, 710 Old Willets Path, Hauppauge, NY 11788 - Tel: 1-631-234-0500 - Fax: 1-631-234-0691

Website: [www.mixers.com](http://www.mixers.com) - Email: [sales@mixers.com](mailto:sales@mixers.com)