



# Ross High Viscosity Dispenser

*Leading the Mixing Industry for over 160 years.*

Filling the void on applications too viscous for standard High Speed Dispensers, the Ross High Viscosity Dispenser is an economical single shaft mixer which is specially designed to mix high viscosity materials rapidly. As the agitator cuts through the viscous product, a lifting action is created allowing the material to fold back over creating a homogeneous mix.

The standard design includes features such as

explosion proof inverter duty motors, heavy duty drives and bearings, safety limit switches for both height limitations and mix can position, adjustable can lock system for use with different size mix vessels, air/oil hydraulic lift system including hand/foot controls, stainless steel wetted parts and stainless steel shaft guard.

**Custom agitator designs are available to meet all of your mixing needs.**



PBA - 1/2 to 2

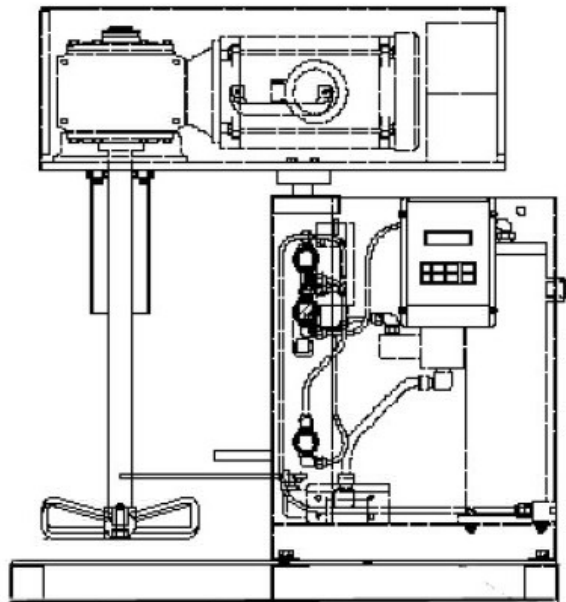

PBA - 5 to 20

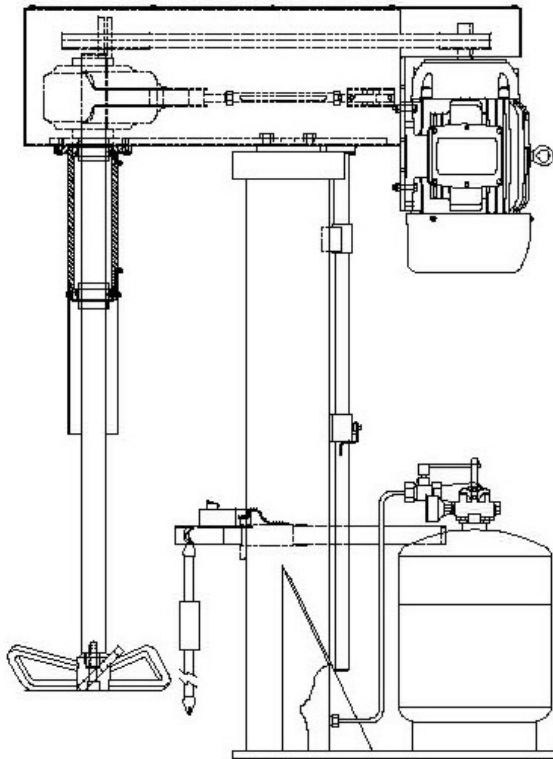

Model	HP	RPM	OAW		OAL		OAH Lowered		OAH Raised		Distance Between Feet		Capacity Water (Gallons)	Weight (Pounds)
			in.	mm	in.	mm	in.	mm	in.	mm	in.	mm		
PBA-1/2	1/2	36-540	16	392	29.5	722	31.75	778	46.75	1145	12	294	1/2-5	480
PBA-1	1	36-540	16	392	29.5	722	31.75	778	46.75	1145	12	294	1/2-5	500
PBA-2	2	36-540	16	392	29.5	722	31.75	778	46.75	1145	12	294	1/2-5	540
PBA-5	5	44-175	28.375	695	55.75	1365	78.75	1918	128.75	3154	N/A		5-150	1900
PBA-7.5	7.5	44-175	28.375	695	55.75	1365	78.75	1918	128.75	3154	N/A		5-250	2000
PBA-10	10	44-175	28.375	695	55.75	1365	78.75	1918	128.75	3154	N/A		50-500	2100
PBA-15	15	44-175	28.375	695	55.75	1365	78.75	1918	128.75	3154	N/A		50-500	2200
PBA-20	20	44-175	28.375	695	55.75	1365	78.75	1918	128.75	3154	N/A		50-500	2300

## Applications

Inks  
 Pigment Dispersions  
 Polyesters  
 Wax Dispersions  
 Press Cakes  
 Adhesives  
 Caulks  
 Epoxies  
 Sealants  
 Lacquers  
 Pastes

The ultimate test -  
 in the Ross Test &  
 Development Center  
 or in your plant.

Call Ross to arrange a demonstration of our PBA and other models. The Ross Test & Development Center is staffed with the most experienced engineers in the business and is fully equipped for quantitative analysis of your results.

Call or E-mail ROSS today. 1-800-243-ROSS, sales@mixers.com.

Call now to speak to an applications engineer. Learn more about the Ross PBA and all of the other Ross products.



CHARLES ROSS & SON COMPANY

P.O. Box 12308  
 710 Old Willets Path  
 Hauppauge, NY 11788  
 Tel: 631-234-0500  
 Fax: 631-234-0691  
 1-800-243-ROSS  
 Website: www.mixers.com  
 E-mail: sales@mixers.com